

---

## PRODUCTION TRACKING AND MANAGEMENT FOR SMEs

**Denish M Chandra, Dikky Setiawan, Muhammad Saka Tauladani,  
Muhammad Al Faraby and Harnan Malik Abdullah**

Brawijaya University

Email: denismchandra@student.ub.ac.id, setyawandicky88@gmail.com,  
sakatauladani54@gmail.com, alfarobi695@gmail.com and  
harnan\_malik@ub.ac.id

---

### ARTICLE INFO

### ABSTRACT

Received:  
**September, 26<sup>th</sup>  
2021**

Revised:  
**October, 14<sup>th</sup>  
2021**

Approved:  
**October, 15<sup>th</sup>  
2021**

The problems experienced by Jazzy Souvenir SMEs are in the form of obstacles in monitoring the souvenir production process and difficulties in calculating the number of souvenirs that have been completed. The purpose of this study was to determine the method of designing PROTIM (Production Tracking and Management) as a monitoring system for the production process to increase production capacity in Jazzy Souvenir SMEs. This study uses qualitative methods with research in the form of program implementation. The implementation of the student creativity program in the field of science and technology application was carried out for three months which was divided into three stages, the first was problem identification and literature study at partner locations. The next stage is software design with the team using video conferencing. While the last stage is socialization, application of tools as well as monitoring and evaluation at SMEs Jazzy Souvenir. The conclusion that can be drawn from this research is that to overcome the obstacles in monitoring the souvenir production process as well as the difficulty in calculating the number of souvenirs that have been completed is to use the PROTIM design method (Production Tracking and Management) as a production process monitoring system to increase production capacity in MSME Jazzy Souvenirs. The existence of this innovation and new technology is very useful for partners in overcoming the problem of increasing production capacity for Jazzy Souvenir SME partner employees.

---

Denish M Chandra, Dikky Setiawan, Muhammad Saka Tauladani,  
Muhammad Al Faraby and Harnan Malik Abdullah. (2021).  
Production Tracking and Management for SMEs. Journal Eduvest.  
1(10): 1122-1128

How to cite:

E-ISSN: 2775-3727

Published by: <https://greenpublisher.id/>

---

**KEYWORDS**

PROTIM, SMEs, Production Tracking



This work is licensed under a Creative Commons Attribution-ShareAlike 4.0 International

---

## INTRODUCTION

Micro, small, and medium enterprises or MSMEs have a very vital role in sustaining economic growth (Putri, 2017). The MSME sector is able to create jobs that then reduce poverty. In addition to playing a role in development and economic growth, MSMEs also have a very important contribution to overcome the problem of unemployment. MSMEs proved to be able to absorb labor (Kristiyanti, 2012). The high growth rate of MSMEs is a source of employment. So that MSMEs are able to increase income through high labor absorption rates (Dewi & Utari, 2014). This means that MSMEs have a strategic role in fighting poverty and unemployment.

The strength of the MSME sector has been proven when Indonesia experienced a financial crisis in 1997-1998 (Putra, 2016). Only the MSME sector is still growing, even after the economic crisis the number of MSMEs has not decreased, it continues to increase (Hafni & Rozali, 2015). UKM Jazzy Souvenir is one of the businesses engaged in making wedding souvenirs. This SME is located at Jl. Halimun No.29 b, Sawahan, Kec. Sawahan, Surabaya City. UKM Jazzy Souvenir has many souvenir orders for weddings. Every month UKM Jazzy Souvenir receives dozens of consumers with each consumer ordering at least 500 souvenir units. Consumers generally order souvenirs for wedding souvenirs. Each month has a total production capacity of 5000 souvenir units. The number of employees of SME Jazzy Souvenir is 15 employees with a division of 5 employees in the sales section in the store and 10 employees in the production unit.

The problems experienced by UKM Jazzy Souvenir in the form of obstacles in monitoring the souvenir production process and difficulty in calculating the number of souvenirs that have been completed. Head of SME Jazzy Souvenir, Agnes Candra explained that during this time she monitored and calculated souvenirs manually by checking directly into the production room and then taking notes using microsoft excel software application. Methods for monitoring and calculating this manual way take a long time and cause double data so that the data becomes biased and inaccurate.

The problem of SME Jazzy Souvenir encourages us to create PROTIM (Production Tracking and Management) technology which is the right technology in the form of IoT-based devices or the Internet of Things to overcome the problems experienced by our partners in monitoring the production of consumer order souvenirs.

PROTIM (Production Tracking and Management) uses the principle of internet of things or IoT-based website application for production process management that is integrated directly into the souvenir counting tool directly or in real time. PROTIM (Production Tracking and Management) uses computerized algorithms so that it is expected to be able to improve the production process in JAZZY SOUVENIR SMEs so as to improve service and production time efficiency.

The purpose of this research is to find out the method of designing PROTIM (Production Tracking and Management) as a production process monitoring system against increasing production capacity in MSMEs Jazzy Souvenir. To find out the working mechanism of PROTIM (Production Tracking and Management) as a production process monitoring system against increasing production capacity in MSMEs Jazzy Souvenir. To find out the impact of the implementation of PROTIM (Production Tracking and Management) as a production process monitoring system to increase production

capacity in MSMEs Jazzy Souvenir.

Manfaat yang diharapkan dari penelitian ini ialah agar dapat memberikan inovasi dan teknologi baru yang sangat berguna bagi mitra dalam mengatasi masalah peningkatan kapasitas produksi pada pegawai mitra UKM Jazzy Souvenir.

## RESEARCH METHOD

This study uses qualitative methods with research in the form of program implementation (Hamilton & Finley, 2019). The implementation of the student creativity program in the field of science and technology application was carried out for three months which was divided into three stages, the first was problem identification and literature study at partner locations (Ameyaw & Chan, 2013). The next stage is software design with the team using video conferencing. While the last stage is socialization, application of tools as well as monitoring and evaluation at UKM Jazzy Souvenir which is located at Jl. Halimun No.29b, Sawahan, Kec. Sawahan, Surabaya City.

The implementation phase in the application of the PROTIM system to Jazzy Souvenir UKM starts from the problem identification phase for Jazzy Souvenir UKM partners. The next stage is literature study and data collection. Then the stage of preparing the PROTIM design. Then perform a function test of the tool. If the tool has passed the function test, socialization and application of the tool will be carried out by partners, then monitoring and evaluation will be carried out. So that the problem of Jazzy Souvenir UKM has been successfully resolved so that PROTIM has met the indicators as shown in Figure 1.

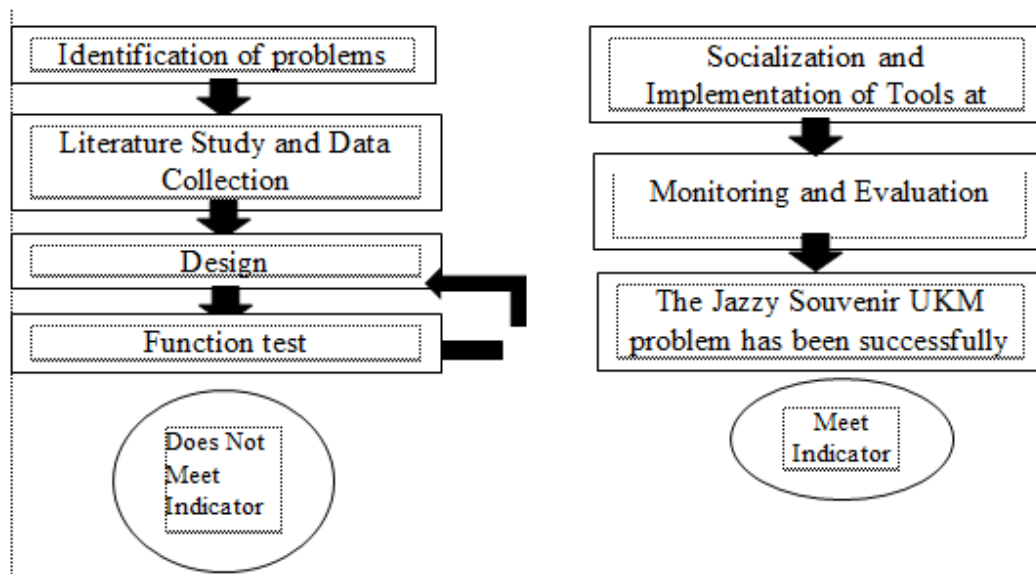

Figure 1. PROTIM Implementation Stage

## RESULT AND DISCUSSION

### A. Identification of problems

Problem identification is carried out by conducting a direct survey to Jazzy Souvenir UKM to see the condition of production management carried out so that it can analyze existing problems. In addition, we also conduct an interview process to confirm

the problems that have been analyzed by holding discussions with partners regarding production process problems to find the right solution by presenting a technology that suits the needs of Jazzy Souvenir UKM so that it can help solve existing problems. Our partners really expect an application or software that can be used for monitoring the production process. Thus, the technology presented in this program is in the form of tool innovation as well as a monitoring system to determine the production process directly which is integrated on the website.

### B. Design

PROTIM is created by combining connected tools and software into a website. The PROTIM mockup is shown in the image as in figure 2.



Figure 2. Display of Administrator or Owner Account

In this display, the owner can see two production statuses, namely active and complete. Active is a production that is still running, the owner can also see the details of the process such as the name, type of souvenir, quantity, starting work, percentage of the process, and completion time.



Figure 3. Display Counting Souvenirs

The counting display is used by employees to calculate the number of souvenirs

that will be included in the production process and souvenirs that will be sent to consumers.

### C. Mechanism of Action

The working mechanism of PROTIM is shown in the system process as shown in Figures 4 and 5.

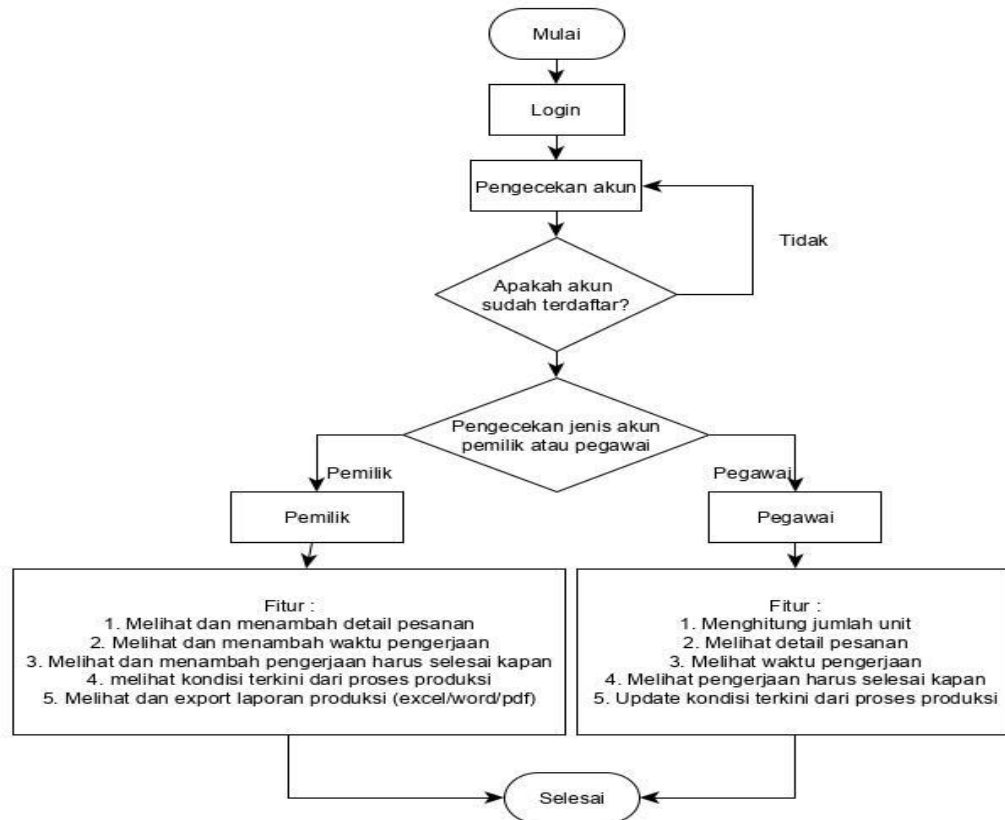

Figure 4. PROTIM System Process

Figure 4 PROTIM system process before entering PROTIM features the user must login for system security and to distinguish features between owners and employees of Jazzy Souvenir.

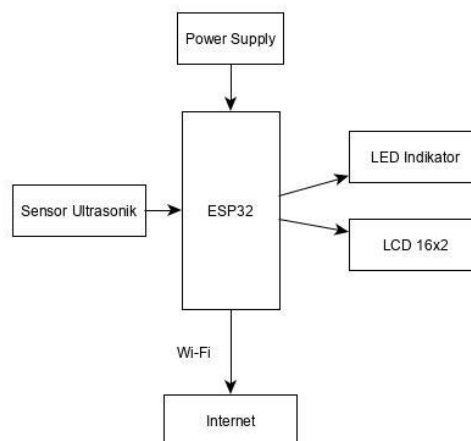

Figure 5. Block Diagram of the PROTIM Calculator System

Figure 5 is a block diagram of the PROTIM tool for the souvenir counter. PROTIM utilizes ultrasonic sensors to determine the distance of objects in front of the PROTIM counter, if there are objects through the counter, the sensor will send distance data to the ESP32. ESP32 receives data from the sensor, if the distance is less than 30 cm then ESP32 will increase the number of previous calculations and then send the calculated numerical data to the server to be displayed on the employee monitor.

### **C. Function Test Tool**

The test of the success of the system design and manufacture is carried out through a tool function test. The function test of the tool is carried out at the Vocational Computer Laboratory of Brawijaya University by looking at the tracking system, management system, and web interface system that has been running as desired. An applied study of the tool system was carried out at Jazzy Souvenir UKM with several trial stages, namely:

1. The function test of the Tracking and Management system is carried out directly at the location of the Jazzy Souvenir UKM partner by means of a simulation.
2. Web Interfaces function test is carried out to find out the results of sensor data processed by ESP32 that can be viewed from the web with appropriate analysis.
3. The overall system function test is carried out on the tracking and management system. The overall work test of the tool is carried out to determine the overall performance of the tool during implementation.

### **D. Socialization and System Implementation in UKM Jazzy Souvenir**

The implementation of the PROTIM system is carried out at partner locations, namely UKM Jazzy Souvenir on Jl. Halimun No. 29 b, Sawahan Regency, Surabaya City. Before the system is implemented, partners are given socialization related to an explanation of system functions and how to operate the system. In addition, a book of Standard Operating Procedures or SOPs for the PROTIM system was provided. Making SOP books is useful to facilitate the delivery of information to partners during the system implementation process related to system operation, system maintenance, as well as assisting in overcoming troubleshooting on the system when it is used.

### **E. Monitoring and Evaluation**

The monitoring and evaluation stages are carried out to find out and monitor how effective the Technology Application Student Creativity Program has been. The goal is to find out the shortcomings of the program so that the authors and partners can make improvements. The evaluation stage will be carried out by comparing the results before and after using PROTIM in monitoring the production process at Jazzy Souvenir UKM.

## **CONCLUSION**

The conclusion that can be drawn from this research is that to overcome the obstacles in monitoring the souvenir production process as well as the difficulty in calculating the number of souvenirs that have been completed is to use the PROTIM design method (Production Tracking and Management) as a production process monitoring system to increase production capacity in MSME Jazzy Souvenirs. The existence of this innovation and new technology is very useful for partners in overcoming

the problem of increasing production capacity for Jazzy Souvenir SME partner employees.

### REFERENCES

- Ameyaw, Ernest Effah, & Chan, Albert P. C. (2013). Identifying public-private partnership (PPP) risks in managing water supply projects in Ghana. *Journal of Facilities Management*.
- Dewi, Ni Putu Martini, & Utari, Tri. (2014). Pengaruh modal, tingkat pendidikan dan teknologi terhadap pendapatan usaha mikro kecil dan menengah (UMKM) di Kawasan Imam Bonjol Denpasar Barat. *E-Jurnal Ekonomi Pembangunan Universitas Udayana*, 3(12), 444-96.
- Hafni, Roswita, & Rozali, Ahmad. (2015). *analisis usaha mikro, kecil, dan menengah (UMKM) terhadap penyerapan tenaga kerja di Indonesia*.
- Hamilton, Alison B., & Finley, Erin P. (2019). Qualitative methods in implementation research: an introduction. *Psychiatry Research*, 280, 1125-16.
- Kristiyanti, Mariana. (2012). Peran strategis usaha kecil menengah (UKM) dalam pembangunan nasional. *Majalah Ilmiah Informatika*, 3(1), 63–89.
- Putra, Adnan Husada. (2016). Peran UMKM dalam pembangunan dan kesejahteraan masyarakat kabupaten Blora. *Jurnal Analisa Sosiologi*, 5(2).
- Putri, Euis Hasmita. (2017). Efektivitas Pelaksanaan Program Pengembangan Usaha Mikro Kecil Dan Menengah (UMKM) Di Kota Samarinda (Studi Pada Dinas Koperasi Dan UMKM Kota Samarinda). *EJournal Administrasi Negara*, 5(1), 5431–5445.