

## HALAL CERTIFICATION ROLE AS MEDIATION IN EFFORTS TO INCREASE HALAL AWARENESS, CUSTOMER VALUE, AND PURCHASING DECISIONS ON DKI JAKARTA'S HALAL CULINARY CONSUMERS

Victor Pascalis Gazali<sup>1</sup>, Fahrul Riza<sup>2</sup>

<sup>1,2</sup> Program Studi Magister Manajemen, Universitas Bunda Mulia, Indonesia

Email: m81220081@student.ubm.ac.id, l1128@lecturer.ubm.ac.id

### ABSTRACT

*The purpose of this study is to determine the role of Halal Certification in improving the relationship between Halal Awareness to Customer Value which results in improved Purchasing Decisions. The research methodology was carried out using quantitative purposive sampling methods with a total of 213 Muslim respondents who ate and drank in restaurants or restaurants in office areas in South Jakarta in 2023 by directly distributing questionnaires. The data analysis technique uses SEM-AMOS version 24. The results of this study prove that the indirect effect of Halal Certification has a mediating role in increasing the influence of Halal Awareness on Customer Value, whereas the direct effect of the influence of Halal Awareness on Customer Value has a negative estimated value and a significant p-value. The higher one's Halal Awareness will make consumers more careful, and critical, and choose a product. This research also proves that Halal Certification has an important role in customer value so that products are guaranteed Halalan Tayyiban. This research implies that it can be a reference for academic research and seminar materials. Business actors can also make strategic planning in business development in product marketing and consumers can participate by not bringing non-halal food and beverages into restaurants or restaurants that have been guaranteed to be Halal. Further research can be developed in the field of strategic management, making the variables Theory of Planned Behavior, Theory of Reasoned Action, and 4P & 4C Marketing Mix as mediating variables.*

**KEYWORDS** Purchasing Decision, Halal Awareness, Customer Value, Halal Certification



***This work is licensed under a Creative Commons Attribution-ShareAlike 4.0 International***

**How to cite:**

**E-ISSN:**

**Published by:**

Victor Pascalis Gazali, Fahrul Riza. (2024). Halal Certification Role as Mediation in Efforts to Increase Halal Awareness, Customer Value, and Purchasing Decisions on DKI Jakarta's Halal Culinary Consumers. *Journal Eduvest*. 4 (3): 977-993

2775-3727

<https://greenpublisher.id/>

## INTRODUCTION

Indonesia is a country with the largest Muslim population in the world, based on data from The Royal Islamic Strategic Studies Center (RISSC) entitled The Muslim 500 2022 edition, the Muslim population in Indonesia reached 231.06 million people or equivalent to 86.7% of the total population of Indonesia. This fact has great potential in developing halal products and services. In the same data, it was recorded that the number of Muslim population in the world reached 1.9 billion, or equivalent to 22% of the total world population (RISSC, 2022). According to a Pew Research Center report, it is estimated that the Muslim population growth rate of 32% could increase to 70% in the next decade or is estimated to reach 3 billion Muslims by 2060 in the next decade. (Kusumastuti, 2020).

This large Muslim population makes the demand for halal products also increase. This growth in the Muslim population is in line with the total amount of expenditure, where The State of the Global Islamic Economy Report 2022 records the total expenditure of the world's Muslim citizens in 2021 in various sectors of the halal industry, such as halal food and beverages, halal pharmaceuticals and cosmetics, halal clothing, halal tourism, halal media and entertainment, and Islamic finance which reached USD 2 trillion. Specifically on food and beverages, the world's Muslims spent USD 1.27 trillion in 2021, and is expected to increase to USD 1.67 trillion by 2025 (Dinar Standard, 2022).

As a country with the largest Muslim population in the world, Indonesia has great potential in the development of the halal industry sector. Based on data from the Industry of the Republic of Indonesia, the expenditure of the Indonesian population on halal products and services amounted to USD 184 billion in 2020 and is projected to continue to grow to USD 281.6 billion in 2050 (Kemenperin.go.id., 2022). Added data from Indonesia Halal Markets Report 2021/2022 (Dinar Standard et al., 2021), expenditure on halal products, especially food, and beverages, amounted to USD 135 billion and is projected to grow to USD 204 billion by 2050 and Indonesia is country with the largest expenditure on food and beverage products in 2020.

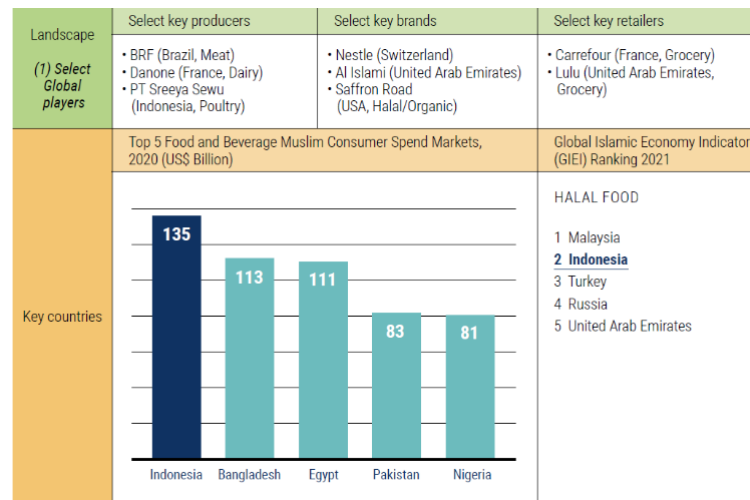

**Figure 1.** Shopping Expenditure on Halal Food and Beverage Products

However, amid large expenditures on halal products, they are still importing. Based on Halal Food data sourced from the State of Global Islamic Economy Report 2022, Indonesia has been ranked 2nd in the Global Islamic Economy Ranking Indicator for the Halal Food category in 2022 (RISSC, 2022) whereas in the 2017/18 report, Indonesia is not included in the top 10 (Dinarstandard, 2017) this can be interpreted as a process towards Indonesia's success in developing the halal product ecosystem, especially halal food and beverage products.

Table 1. SGIER Rankings 2017/18 and 2022

TOP10	<i>State of Global Islamic Economy Report (SGIER)</i>				
	2017/2018	2018/2019	2019/2020	2020/2021	2022
<i>GIE Indicator Score by Country</i>	-	10th place	4th place	4th place	4th place
<i>Halal Food</i>	-	-	-	4th place	2nd place
<i>Islamic Finance</i>	10th place	10th place	5th place	6th place	6th place
<i>Halal Travel / Muslim Friendly Travel</i>	4th place	4th place	4th place	6th place	-
<i>Modest Fashion</i>	-	2nd place	3rd place	3rd place	3rd place
<i>Halal Media and Recreation</i>	-	-	-	6th place	-
<i>Halal Pharmaceuticals and Cosmetics</i>	8th place	-	-	5th place	9th place

Source: Dinar Standard 2017-2022 (processed by researchers)

The increasing amount of expenditure from the consumption of halal products and the increasing number of Muslim population has the opportunity to continue to develop halal business opportunities, while based on the *State of Global Islamic Economic Report* categorizes the Islamic economic sector among others, Islamic Finance, Halal Food, Halal Travel / Muslim Friendly Travel, Modest Fashion, Halal Media and Recreation, and Halal Pharmaceuticals and Cosmetics. This opportunity is strongly supported by several factors (Dinar Standard, 2022), among others, 25% of the world's population is Muslim, the growth of the Muslim population has accelerated in 6 years, the development of connectivity-based marketing has grown, increased awareness of the importance of health not only the taste or pleasure of food, increased welfare due to understanding of Islamic Finance rules, national Islamic Economics strategies supported by government regulations and compliance with halal among Muslims.

Wartasidoarjo.Pikiran-Rakyat (15 June 2021) Reported that the halal industry is not only a religious doctrine but also a business opportunity the halal industry business is still controlled by Muslim-majority countries, this is evidenced by the fact that some non-Muslim majority countries make the Islamic economy the center of economic growth in their respective countries through the development of the halal industry sector. In addition, several other non-Muslim countries are trying to enter the halal industry competition, which indicates that halal principles are becoming a global trend that is not dominated by the interests of Muslims.

To ensure that the halal industry is by Islamic religious rules, halal certification is needed. In addition to the issue of assurance for Muslims, the purpose of implementing halal certification is to increase the value of products felt by customers. However, there are other consequences of implementing the halal certification process, which will increase business operational costs which have an impact on price increases. However, it is expected that with increased awareness, consumer and producer knowledge about the importance of halal certification of a product and service purchased will certainly increase the value of products and services so that consumer sensitivity to prices will be reduced.

A systematic Mapping Study conducted by Kusumastuti (2020) stated that the desire of people in Indonesia to buy halal products is very high. This high desire to buy specifically packaged halal food and beverage products is examined by (Atikah, 2017; Muslimah, Hamdani Irfani, 2018; Yudika, 2018; Singgih, 2018; Budiman, 2019; Putri, 2019), and further on halal restaurants researched by (Napitasari, 2018; Mardiani, 2019; Khadijah and Wulandari, 2020). This purchase desire is closely related to needs and purchasing decisions where several studies show high purchase interest is directly proportional to purchasing decisions as evidenced by research results where purchase interest is significant and positive for purchase decisions (Sunardi, Sari, & Cahyani, 2021; Paramita, Ali, & Dwikoco, 2022; Bakhtiar & Sunarka, 2023). It can be interpreted as proof that the majority of Indonesian Muslims want products with halal guarantees.

Amid the high need and desire to consume halal products, the fact is that all halal certification guarantees have not been fulfilled, especially at the scale of micro, small, and medium enterprises. Based on BPJPH Halal Information System Data until November 5, 2021, 31,529 business actors applied for halal certification,

including micro businesses totaling 19,209 or 60.92%, small businesses totaling 5,099 or 16.17% of the total MSE actors as much as 76% (Kemenag.go.id., 2021). Until now, the Government through BPJPH has carried out a *Self-Declare* program to help micro, small, and medium enterprises (MSMEs) facilitate the process of certifying halal products for free. Based on the official website of the Ministry of Kemenag.go.id, in 2023 the Halal Product Assurance Organizing Agency (BPJPH) will re-open the Free Halal Certification (Sehati) program with a quota of 1 million halal certificates (Kemenag.go.id., 2022).

To support the halal ecosystem in Indonesia, the National Committee for Sharia Economy and Finance (KNEKS) has initiated the establishment of Safe and Healthy Halal Culinary Zones (Zona KHAS) in several locations, namely in South Jakarta and Surabaya, where all levels and groups of society can visit to seek information and as a means of education to increase awareness and behavior to produce and consume halal food, safe, and sound. From the business actor's side, providing halal, safe, and healthy products is a form of real concern for consumers to consume halal-certified, safe, and healthy products, and can provide a sense of security and calm (KNEKS, 2022).

The purpose of this study is to analyze the effect of halal awareness among Muslim consumers in increasing customer value for food and beverages among Muslim consumers. Benefits in the field of management, this research can be developed again in the future to advance the economy of Micro, Small, and Medium Enterprises (MSMEs) as a decision-making consideration in making and developing halal product marketing strategies.

### **Theoretical Background**

Halal and haram are two important concepts derived from the *Qur'an*. *Halal* is defined as "permitted to be consumed or done", whereas haram denotes "something that is not permitted to be consumed or done" (Hosain, 2021). The provisions of halal and haram come from *Allah Subhanahu wa ta'ala* which has been explained in *the Qur'an* and *Hadith*, as explained in the tafsir Lajnah Pentashihan Mushaf Al-Qur'an et al. (2013), "*Wahai manusia! Makanlah dari (makanan) yang halal dan baik yang terdapat di bumi, dan janganlah kamu mengikuti langkah-langkah setan. Sungguh, setan itu musuh yang nyata bagimu*" (al-Baqarah 2:168).

Halal Awareness is defined as the knowledge of each individual regarding their understanding of halal and haram (Wirakurnia et al., 2021). Halal Certification relates to a form of guaranteeing the halalness of a product according to Islamic Law. Each country has the same references, namely the Al-Qur'an and Hadith, but they are only differentiated by authority to simplify the process of issuing Halal Certification (Lutfika et al., 2022; Wirakurnia et al., 2021). The halal label is proof that the product is declared halal and is an integral part of issuing halal certification. Products that have received halal certification are required to include a halal label on their products, with the aim of making it easier for consumers to determine which product they want to buy. Thus, business actors agree that a product labeled halal has an influence on product sales (Helmi et al., 2019). Other research explains that a direct relationship with customer value has a significant positive impact on

purchasing decisions (Asyhari & Yuwalliatin, 2022; Septiano & Sari, 2021). Other research explains that the halalness of a product is not limited to the ingredients contained in it but also the Islamic values and cleanliness in it (Pratiwi et al., 2022; Wibowo & Mandusari, 2018), proposed hypothesis:

**H<sub>1</sub>: Halal Awareness has a positive and significant effect on Halal Certification.**

**H<sub>2</sub>: Halal Certification has a positive and significant effect on Customer Value.**

**H<sub>3</sub>: Halal Awareness has a positive and significant effect on Customer Value.**

Customer Value is defined as consumers preferences sometimes subjectively that evaluate product and service attributes, cost, time and effort. Every consumer has different needs & wants, marketers should consider and understand the target market and the value of various market segments. Higher customer value makes more satisfaction and purchase decisions then expect repeat purchases (Hiray & Anjum, 2022). Purchase Decision is defined as the process of selecting two or more alternative options starting from searching, evaluating product searches until consumers choose one of these options (Sandria et al., 2022). Products that are Halal certified will be directly proportional to high halal awareness, and halal awareness itself will influence decisions in purchasing halal food (Setyaningsih & Marwansyah, 2019; Efendi, 2020; Fathoni et al., 2023), while other studies have concluded that there is a significant positive direct relationship between customer value and purchasing decisions (Asyhari & Yuwalliatin, 2022; Rahman, 2020; Septiano & Sari, 2021), proposed hypothesis

**H<sub>4</sub>: Customer Value has a positive and significant effect on Purchasing Decisions.**

**H<sub>5</sub>: Halal Certification has a positive and significant effect on Purchasing Decisions mediated by Customer Value.**

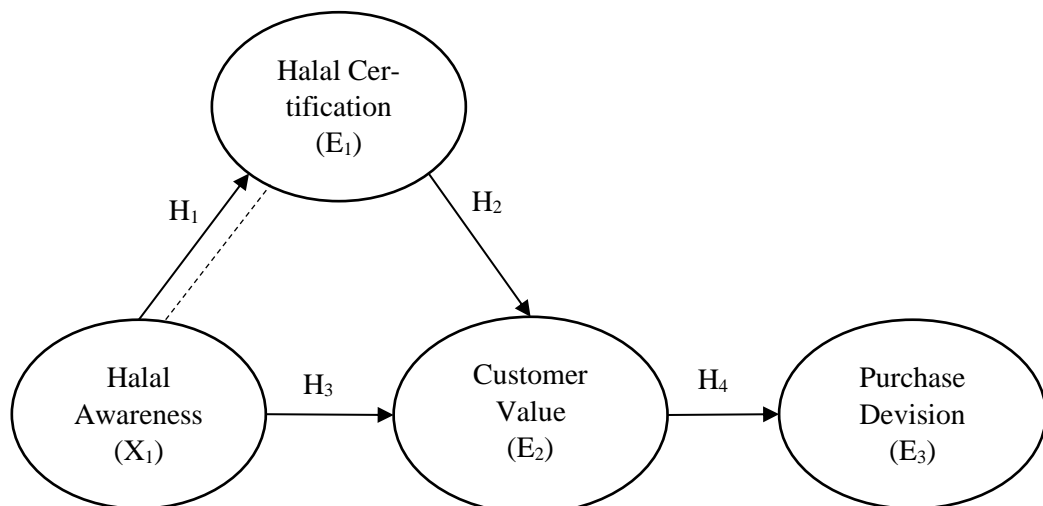

**Figure 2.** Research Framework

## RESEARCH METHOD

This study used quantitative methods with data analysis techniques, namely descriptive analysis and associative analysis. Data analysis uses structural model equations or SEM and the data is analyzed using AMOS v.24 software. Quantitative research is a systematic scientific study of parts and phenomena and their relationships (Toyo, 2019), While Sugiyono (2017) Describes quantitative methods as scientific research that uses numbers and statistical analysis because it has fulfilled scientific principles, namely concrete/empirical, objective, measurable, rational, systematic and *replicable*. According to (Sugiyono, 2017) Descriptive analysis is analyzing data by describing or describing data that has been collected as it is without intending to make generalized conclusions or generalizations, while associative analysis is research that aims to determine the relationship between two or more variables.

This study is to examine the relationship and influence between variables including exogenous variables (Halal Awareness variables), endogenous variables (Halal Certification variables, Customer Value, and Purchase Decisions), and mediation variables (Halal Certification variables). The data source used is primary data using a questionnaire which is scheduled for offline distribution of the questionnaire in July – August 2023. Population of this research is DKI Jakarta's consumers with sample criteria Muslim consumers and visited, ate, drank on registered Halal Certification's restaurant. Questionnaire data collected from respondents will be processed using SEM (Structural Equations Model) data analysis with AMOS v.24 software.

## RESULT AND DISCUSSION

### Analysis Results

Questionnaire data collection in this study used a Google form questionnaire that was distributed directly at the research location. The final result was 213 because 99 did not meet the criteria (2 respondents answered on a scale of 3 "Neutral" on all questionnaire questions, and 97 consumers were non-Muslims). A total of 213 respondents who were accepted according to the criteria were carried out data processing using the AMOS application version 24.

### Instrument Test

In this study, *Confirmatory Factor Analysis* (CFA) testing was carried out, namely through the construct process of the Validity Test, Reliability Test, and *Goodness of Fit Test* (Ghozali, 2017).

### Validity Test

According to (Hair et al., 2019) The validity test criteria are *a loading factor* value greater than or equal to 0.5 ( $\text{Loading Factor} \geq 0.5$ ) and ideally greater than or equal to 0.7 ( $\text{Loading Factor} \geq 0.7$ ). In this study, all indicators already have a *loading factor* value above 0.6 so all indicators are considered valid.

Table 2. Validity Test Results

Variable	Indicator	Estimate	Result
X1 Halal Awareness	X11	0,792	Valid
	X12	0,711	Valid
	X13	0,729	Valid
	X14	0,688	Valid
	X15	0,737	Valid
E2 Customer Value	E21	0,762	Valid
	E22	0,827	Valid
	E23	0,709	Valid
	E24	0,805	Valid
	E25	0,728	Valid
	E26	0,781	Valid
E3 Purchase Results	E31	0,874	Valid
	E32	0,869	Valid
	E33	0,710	Valid
	E34	0,741	Valid
	E35	0,746	Valid
	E36	0,746	Valid
E1 Halal Certification	E11	0,757	Valid
	E12	0,756	Valid
	E13	0,795	Valid
	E14	0,780	Valid
	E15	0,732	Valid
	E16	0,762	Valid
	E17	0,768	Valid
	E18	0,752	Valid
	E19	0,803	Valid
	E110	0,805	Valid
	E111	0,733	Valid
	E112	0,704	Valid
	E113	0,806	Valid
	E114	0,748	Valid
	E115	0,722	Valid
	E116	0,768	Valid

### Reliability Test

According to (Ghozali, 2017) variable is said to be *Reliable* if the value of *the loading factor* is greater than or equal to 0.7 (koef. The  $\geq 0.7$ ) and the AVE value is greater than or equal to 0.5 (AVE  $\geq 0.5$ ). In this study, all values of the reliability coefficient were above 0.7 and all AVE values were above 0.5 so the test was said to be *Reliable*.



Table 3. Reliability Test Results

Variable	Koef. Reliability	AVE	Result
X1 (Halal Awareness)	0,852	0,536	Reliable
E1 (Halal Certification)	0,897	0,593	Reliable
E2 (Customer Value)	0,764	0,764	Reliable
E3 (Purchase Results)	0,957	0,581	Reliable

**Goodness of Fit Test (Model Suitability)**

The following are the results of measuring the conformity of the model after validity tests and reliability tests:

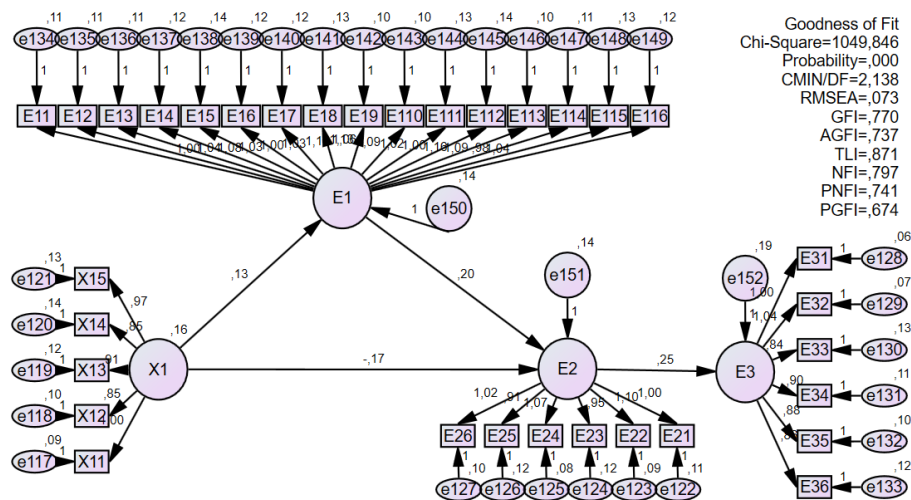
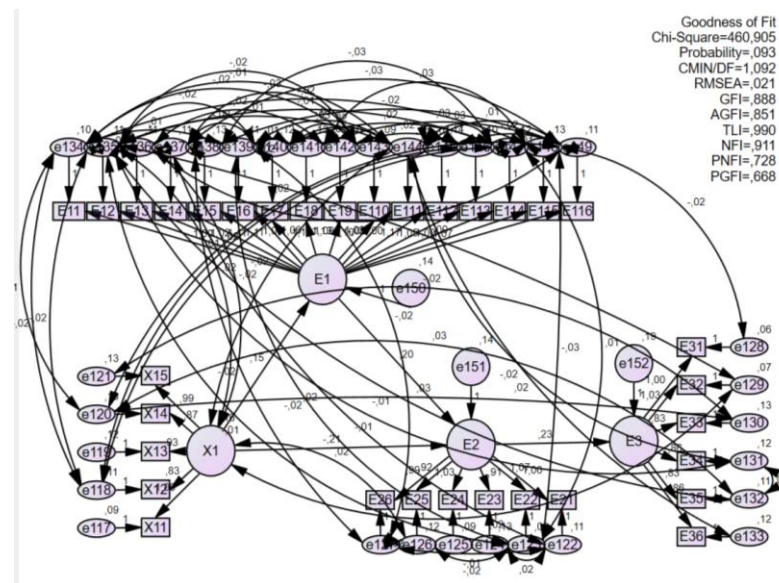

Figure 3. Structural Model AMOS 24

Based on Figure 3. the measurement results do not meet the *Goodness of Fit criteria*. The probability value has not met the criteria, which is above 0.05 ( $\geq 0.05$ ). To overcome models that have not entered the *Good Fit criteria*, Modification Indices are carried out. *Modification Indices* calculate any possible relationships between variables and/or indicators that are not estimated in the model (Ghozali, 2017). The following model has been carried out *Modification Indices*.



**Figure 4.** Structural Model After Modification of Indices

Based on Figure 4. after Modification Indices are carried out, *the* Goodness of Fit test results are *Good Fit* in Table 4.

Table 4. Goodness of Fit Results

Index	Criteria (Ghozali, 2017)	Result	Criteria
<i>Chi-Square</i>	Expected small	460,905	( <i>Good Fit</i> )
<i>Probability</i>	$\geq 0,05$	0,093	( <i>Good Fit</i> )
RMSEA	$\leq 0,08$	0,021	( <i>Good Fit</i> )
TAG	$\geq 0,90$	0,990	( <i>Good Fit</i> )
CFI	$\geq 0,90$	0,992	( <i>Good Fit</i> )
NFI	$\geq 0,90$	0,911	( <i>Good Fit</i> )
RMR	$\leq 0,05$	0,024	( <i>Good Fit</i> )

**Discussion**

***Halal awareness has a positive and significant effect on Halal Certification***

The hypothesis (H1) is accepted, shown at a CR value of 2.098 and a *p-value* of 0.036.

Tafsir Hadits Imam An-Nawawi: “Dan makanlah dari apa yang telah diberikan Allah kepadamu sebagai rezeki yang halal dan baik, dan bertakwalah kepada Allah yang kamu beriman kepada-Nya.” (Q.S. Al-Maidah: 88). It is the duty of Muslims to obey Allah Almighty and the Messenger of Allah in regard to food that *halalan thayyiban* (Napitasari, 2018). Halal Certification is evidence issued by the Halal Product Assurance Organizing Agency (BPJPH) which has gone through an audit process from the Halal Insurance Agency (LPH) and the determination of Fatwas from the Indonesian Ulema Council (Gerungan & Karina, 2019). This research is supported by research that suggests that Indonesian people, especially

Muslims with halal awareness, will certainly understand and demand halal products and Halal Certification is a form of guarantee (Anas et al., 2023; Nafis, 2019; Rido & Sukmana, 2021; Syafrida & Hartati, 2019). Added by research Hasmi et al. (2022) which states that halal certification is a form of concern from consumers where consumers will see and check the halal label before making a purchase.

***Halal Certification has a positive and significant effect on Customer Value***

The hypothesis (H2) is accepted, indicated by a CR value of 2.598 and a *p-value* of 0.010.

Halal certification is a form of guarantee that a product is protected from all forms of haram and *syubhat* and consumers can be safe in consuming food and beverages (Cupian et al., 2023). Tafsir Hadits Imam An-Nawawi: *“From Abu Abdillah Nu'man bin Basyir radhiallahuanhu he said: I heard Rasulullah SAW say: Indeed, what is halal is clear and what is haram is clear. Between the two there are doubtful (vague) matters that are not known to many people. So whoever is afraid of doubt means he has saved his religion and honor. And whoever falls into a matter of doubt will fall into a matter that is forbidden. Just as a shepherd grazes his animals around (a field) where it is forbidden to enter, so gradually he will enter it. Know that every king has prohibitions and Allah's prohibitions are what He has forbidden. Know that within you there is a lump of flesh, if it is good then the whole body is good and if it is bad then the whole body is bad; know that he is the heart “. (Hadith 6<sup>th</sup> Bukhori and Muslim).* This research is supported by research that suggests that quality assurance of a product has an influence on customer value (Ibrahim, 2022; Kumbara, 2021) and especially product quality assurance through Halal Certification will have the impact of increasing Customer Value in order to avoid illegal cases and *syubhat* (Pratiwi et al., 2022; Wibowo & Mandusari, 2018). Halal has been guaranteed through halal certification, all aspects are not limited to only the ingredients contained in the product so that halal certification can guarantee the values that must be carried out by Muslims (Hasmi et al., 2022)

***Halal awareness has a positive and significant effect on Customer Value.***

The hypothesis (H3) is rejected, indicated by a CR value of -2.691 and a *p-value* of 0.007.

Muslims are commanded by Allah Almighty to consume attentively their food *“Maka hendaklah manusia itu memerhatikan makanannya.”* (Q.S. ‘Abasa: 24) dan *“Maka makanlah yang halal lagi baik dari rezeki yang telah diberikan Allah kepadamu; dan syukurilah nikmat Allah, jika kamu hanya kepada-Nya saja menyembah.”* (Q.S. An-Nahl: 114). The more public awareness about the halalness of a product, the more critical, selective, and careful people will be in choosing food and drinks in a restaurant or restaurant (Agistya & Khajar, 2022; Anas et al., 2023), In addition, access to information, education, religiosity about halal, haram and *they* greatly influence consumers in choosing and meeting food and drink needs (Safitri & Sa’dudin, 2022). This research is supported by research that has been conducted

by (Agistya & Khajar, 2022; Anas et al., 2023; Safitri & Sa'dudin, 2022) that increasing halal awareness then there a change in Customer Value in choosing and consuming food and drink in restaurants or restaurants if there is no Halal Certification. The higher a person's understanding and awareness, the more it will affect problems related to the values contained in a product (Hendradewi et al., 2021). Specifically on halal awareness, the more aware of religious understanding, the more it will affect attitudes that are in harmony with the Qur'an and the Sunnah (Rektiansyah & Auwalin, 2022).

***Customer Value has a positive and significant influence on Purchasing Decision***

The hypothesis (H4) is accepted, indicated by a CR value of 2.726 and a *p-value* of 0.007.

Tafsir Hadits Imam An-Nawawi: “Hai sekalian manusia, makanlah yang halal lagi baik dari apa yang terdapat di bumi, dan janganlah kamu mengikuti langkah-langkah syaitan; karena sesungguhnya syaitan itu adalah musuh yang nyata bagimu.” (Q.S. Al-Baqarah: 168). Customer value is an emotional bond between the seller and buyer after a purchase transaction and the use of the product is not limited only to functional goods but also services and additional value (Mayasari & Anasrulloh, 2023). This research is by research conducted by (Mahatta & Heryenzus, 2023; Mayasari & Anasrulloh, 2023) which suggests that customer value has an influence on consumers in making choices and deciding purchases safely and comfortably. Customer value has a *direct effect* or *indirect effect* on making decisions in buying a product (Agusty & Muttaqin, 2022; Larissa, 2020; Sanjaya, 2020; Simanjuntak & Surabayaarta, 2021). The values that have been guaranteed by halal certification also greatly affect the community, especially Muslims, awake and protected (*himayatul ummah wawiqoyatuha*) from food and drinks that are not halal for their lives so that Muslims do not need to hesitate in buying a product (Baskoro et al., 2023).

***Halal awareness affects Customer Value mediated by Halal Certification***

The hypothesis (H5) is accepted, indicated by the *p-value of indirect effect (user-defined estimand)* 0.024 greater than the *p-value of direct effect* 0.007 so that a mediation role has occurred. Halal certification as mediation can affect Halal Awareness of Customer Value. This shows the more selective or careful consumers are in buying a product (Agistya & Khajar, 2022), with the existence of Halal Certification can remind Customer Value (Musthofa & Burhanudin, 2021; Nafis, 2019; Pratiwi et al., 2022; Wibowo & Mandusari, 2018) and maintain consistency in consuming halal food and beverages (Safitri & Sa'dudin, 2022). The more concerned and aware consumers are of a product will be helped by the existence of a halal certificate, this proves that halal certification will help convince consumers (Hashmi et al., 2022; Toyo, 2019).

## CONCLUSION

Research that has been conducted proves that Halal Certification has a role in increasing Customer Value and Purchasing Decisions. Before the mediation of Halal Certification, Halal Awareness had a negative influence on Customer Value which means that the higher the Halal Awareness owned by consumers, the Customer Value decreases. After the mediation of Halal Certification, the influence of Halal Awareness becomes positive on Customer Value.

The following are the details of the results of research conducted on Muslim respondents in DKI Jakarta during the period July – August 2023: a) First results of this study prove that the first hypothesis of Halal Awareness (X1) has a positive and significant effect on Halal Certification (E1) accepted. Halal awareness plays an important role in encouraging consumers to be more concerned with Halal Certification as a guarantee of food and beverage products to avoid Haram and *Syubhat*. b) Second results of this study prove that the second hypothesis is accepted, Halal Certification (E1) has a positive and significant effect on Customer Value (E2). Halal certification as a form of guarantee of a product plays an important role in increasing Customer Value to avoid Haram and *Syubhat*. c) Third results of this study prove that the third hypothesis is rejected, Halal Awareness (X1) has a negative value on Customer Value (E2). This is because the higher consumer Halal Awareness will make more critical, thorough, or careful in choosing a food and beverage product. d) Fourth results of this study prove Customer Value (E2) has a positive and significant impact on Purchase Decisions (E3). Customer Value proves to have an impact that is compared to the Purchase Decision, so the higher the Customer Value the Purchase Decision will increase. e) Fifth results of this study prove Halal Awareness (X1) has a positive and significant effect on Customer Value (E2) mediated by Halal Certification (E1). The hypothesis is accepted, Halal Certification can increase and change the value that was originally the negative influence of Halal Awareness on Customer Value without the existence of Halal Certification medasi into a positive influence of Halal Awareness on Customer Value after mediation of Halal Certification.

This research expected to be input on Halal Certification National Seminar to encourages creating halal ecosystem form upstream to downstream, then help managerial consideration on profit organisation (e.g. Food and Beverages industries) knowing and understanding Indonesian's consumers needs and wants so can provides Halal Food and Beverages in accordance with Al-Qur'an and Hadith. Other that, consumers should participates to maintaining Halal by not carrying non-halal Food & Bavarages to restaurants. For the next research, could expanding and adding some variables that form Theory Planned Behaviour or Extended Planned Behaviour, muamalah, marketing mix and strategic management.

## REFERENCES

- Agusty, L. E., & Muttaqin, A. A. (2022). Analisis Pengaruh Label Halal, Kesadaran Halal, dan Persepsi Atas Produk Halal Dalam Pembelian Kosmetik Halal. *Islamic Economics and Finance in Focus*, 1(4), 373–387. <https://doi.org/10.21776/ieff.2022.01.4.08>

- Anas, M., Saputro, A. R., & Wahdah, H. (2023). Persepsi Halal dan Pemahaman Sertifikasi Halal: Studi Deskriptif Analitik. *MISYKAT AL-ANWAR: Jurnal Kajian Islam Dan Masyarakat*, 6(1), 1–12. <https://jurnal.umj.ac.id/index.php/MaA16/index>
- An-Nawawi, I. (2005). *Hadits Arbain An-Nawawiyah (Agus Waluyo, Terjemah)*. AW Publisher.
- Asyhari, A., & Yuwalliatin, S. (2022). Moderating role of customer value on the effect of animosity, ethnocentrism and religiosity toward purchase decision: study on Chinese cosmetic. *Jurnal Siasat Bisnis*, 26(2), 138–153. <https://doi.org/10.20885/jsb.vol26.iss2.art2>
- Baskoro, W., Suhasti, W., & Winarno, Moh. W. (2023). Analisis Konsumsi Simbolis Sebagai Variabel Moderator Antara Pengaruh Halal Lifestyle Terhadap Minat Pembelian Produk Perbankan Syariah. *IBSE Economic Journal*, 2(1), 42–56. <https://jurnal.steijogja.ac.id/index.php/ibseej>
- Cupian, Meilasari, K., & Noven, S. A. (2023). Pengaruh Sertifikasi Halal, Kesadaran Halal dan Bahan Makanan Terhadap Minat Beli Produk Makanan Halal Studi Masyarakat Muslim di Kota Banjar. *JIEI Jurnal Ilmiah Ekonomi Islam*, 9(1), 135–142.
- Dinar Standard. (2022). *State of the Global Islamic Economy Report 2022: Unlocking Opportunity*.
- Dinar Standard, Indonesia Halal Lifestyle Center, & Bank Indonesia. (2021). *Indonesia Halal Markets Report 2021/2022*.
- Dyah Setyaningsih, E., & Marwansyah, S. (2019). The Effect of Halal Certification and Halal Awareness through Interest in Decisions on Buying Halal Food Products. *SYI'AR IQTISHADI: Journal of Islamic Economics, Finance and Banking*, 3(1), 64–79. [www.republika.go.id](http://www.republika.go.id)
- Efendi, A. (2020). The Effect of Halal Certification, Halal Awareness and Product Knowledge on Purchase Decisions for Halal Fashion Products. *Journal of Digital Marketing and Halal Industry*, 2(2), 145–154. <https://doi.org/10.21580/jdmhi.2020.2.2.6160>
- Fathoni, M. A., Faizi, & Sari, R. (2023). Determinasi Pembelian Makanan Halal Melalui Platform Digital: Kesadaran Halal Sebagai Variabel Mediasi. *Jurnal Ilmiah Ekonomi Islam*, 9(01), 45–54. <https://doi.org/10.29040/jiei.v9i1.7100>
- Gerungan, K., & Karina, P. (2019). Analisa Pengaruh Kesadaran Halal Terhadap Minat Beli Pelanggan di Restoran Surabaya. *Jurnal Hospitality and Manajemen Jasa*, 7(2), 171–182.
- Ghozali, I. (2017). *Model Persamaan Struktural Konsep dan Aplikasi Dengan Program AMOS 24 Update Bayesian SEM Edisi 7*.
- Hair et al. (2019). *Multivariate Data Analysis 8th ed.*
- Hasmi, Z. P., Fasa, M. I., & Soeharto. (2022). Zhofrani Putri Hasmi, Muhammad Iqbal Fasa, Soeharto. (2022). Perilaku Halal Life Style Terhadap Keputusan Pembelian Konsumen. *Karismapro: Jurnal Manajemen*, 31(2), 99–106. <https://doi.org/https://doi.org/10.53675/karismapro.v13i2.255>
- Helmi, B. S., Hidayat, K., & Fakhry, M. (2019). Pengaruh Undang Undang Jaminan Produk Halal Terhadap Pengembangan Produk Jamu Madura. *Jurnal Pamator*, 12(2), 100–107.
- Hendradewi, S., Mustika, A., & Darsiah, A. (2021). Pengaruh Kesadaran Halal dan Label Halal Terhadap Minat Beli Mie Instan Korea Pada Remaja Sekolah di Jakarta. *Jurnal Ilmiah Pariwisata*, 26(2), 204–212. <https://doi.org/10.30647/jip.v26i2>
- Hiray, A. P., & Anjum, A. (2022). Customer Value: A Systematic Literature Review. *Journal of Positive School Psychology*, 6(2), 2999–3003. <http://journalppw.com>



- Hosain, M. S. (2021). Branding “Halal”: application of a certain religious emotion to attract a specific customer segment. *PSU Research Review*, 5(3), 195–200. <https://doi.org/10.1108/PRR-12-2020-0043>
- Ibrahim. (2022). Pengaruh Labelisasi Halal Produk Kemasan Terhadap Keputusan Pembelian Konsumen (Studi Kasus Pada Dinas Syariat Islam Kab. Pidie). *Jurnal Ekonomi Syariah Dan Bisnis Islam*, 1(1), 1–14. [www.Unisba.ac.id](http://www.Unisba.ac.id)
- Kemenag.go.id. (2021, November 19). *Update Sertifikasi Halal di Indonesia: Ekspektasi dan Kenyataan*. <https://kemenag.go.id/read/update-sertifikasi-halal-di-indonesia-ekspektasi-dan-kenyataan-8njgk>
- Kemenag.go.id. (2022, March 11). *Sertifikasi Halal Gratis 2023 Dibuka, Ada 1 Juta Kuota*. <https://kemenag.go.id/pers-rilis/sertifikasi-halal-gratis-2023-dibuka-ada-1-juta-kuota-69hqib>
- Kemenperin.go.id. (2022, September 30). *Industri Halal Berperan Penting dalam Pemulihan Ekonomi, Kemenperin Luncurkan IHYA 2022*. <https://kemenperin.go.id/artikel/23586/ghs>
- KNEKS. (2022). *Insight Islamic Economy Bulletin: Zona Kuliner Halal dan Sehat*. [https://kneks.go.id/storage/upload/1664882189-Draft%20Buletin%20KNEKS\\_4.pdf](https://kneks.go.id/storage/upload/1664882189-Draft%20Buletin%20KNEKS_4.pdf)
- Kumbara, V. B. (2021). Determinasi Nilai Pelanggan dan Keputusan Pembelian: Analisis Kualitas Produk, Desain Produk dan Endorse. *JIMT: Jurnal Ilmu Manajemen Terapan*, 2(5), 604–630.
- Kusumastuti, D. (2020). Minat Beli Produk Halal di Indonesia, Studi Pemetaan Sistematis. *Mabsya: Jurnal Manajemen Bisnis Syariah*, 2(2), 27–50.
- Lajnah Pentashihan Mushaf Al-Qur’an, Badan Libang Diklat Kementerian Agama RI, & Lembaga Ilmu Pengetahuan Indonesia. (2013). *Makanan dan Minuman dalam Perspektif Al-Qur’an dan Sains (Tafsir Ilmi)*. Lajnah Pentashihan Mushaf Al-Qur’an.
- Larissa, I. (2020). Analisis Pengaruh Content Marketing Terhadap Repeat Purchase dengan Customer Value dan Customer Engagement Sebagai Variabel Intervening pada Traveloka di Surabaya. *Jurnal Strategi Pemasaran*, 7(1), 304–316.
- Lutfika, E., Kusnandar, F., & Hunaefi, D. (2022). Comparative Analysis and Harmonization of Global Halal Standards. In *International Journal of Halal Research* (Vol. 4, Issue 1).
- Mahatta, & Heryenzus. (2023). Pengaruh Kualitas Produk, Promosi dan Nilai Pelanggan Terhadap Keputusan Pembelian di PT Weedo Niaga Global. *ECo-Buss: Economy and Business*, 6(1), 53–65.
- Mayasari, N., & Anasrulloh, M. (2023). Pengaruh Harga dan Nilai Pelanggan Terhadap Keputusan Pembelian Jasa Layanan Grabfood Pada Mahasiswa (Studi pada Mahasiswa Semester VII Program Studi Pendidikan Ekonomi Universitas Bhinneka PGRI). *Jurnal Edueco*, 6(2), 26–36.
- Musthofa, A., & Burhanudin. (2021). Konsumen Muslim: Pengetahuan Produk Halal dalam Keputusan Pembelian Makanan. *El-Jizya: Jurnal Ekonomi Islam*, 9(1), 81–97. <http://ejournal>.
- Nafis, M. C. (2019). The Concept of Halal and Thayyib and Its Implementation In Indonesia. *Journal of Halal Product and Research*, 2(1), 1–5.
- Napitasari, A. (2018). Analisis Minat Beli Konsumen Pada Restoran Bersertifikasi Halal MUI di Daerah Istimewa Yogyakarta Tahun 2018 (Studi Kasus: Konsumen Waroeng Steak and Shake, Gudeg Yu Djum, Bakso Betesda 74) Amarinda Napitasari. *Jurnal Pendidikan Ekonomi*, 7(5), 488–500.

- Pratiwi, N., Parakkasi, I., Darussalam, A. Z., Studi, P., Islam, E., & Makassar, A. (2022). Pengaruh Sertifikasi dan Labelisasi Halal Terhadap Perilaku Pembelian Produk Mi Samyang (Studi Kasus di Kabupaten Ujung Bulu Kabupaten Bulukumba). *Ekonomika*, 06(02), 1–15.
- Rahman, A. (2020). Pengaruh Citra Merek, Kepercayaan Merek, Promosi dan Nilai Pelanggan Terhadap Keputusan Penggunaan Jasa GOJEK (Studi Kasus Pada PT. Aplikasi Karya Anak Bangsa di Kota Banjarmasin). *At-Tadbir: Jurnal Ilmiah Manajemen*, 4(1). <https://doi.org/10.31602/atd.v4i1.2623>
- Rektiansyah, R. R., & Auwalin, I. (2022). Analisis Dampak Kesadaran Halal dan Label Halal terhadap Niat Beli Mie Instan Korea Pada Remaja di Sumenep Melalui Sikap. *Jurnal Ekonomi Syariah Teori Dan Terapan*, 9(5), 600–616. <https://doi.org/10.20473/vol9iss20225pp600-616>
- Rido, M., & Sukmana, A. H. (2021). The Urgence of Halal Certification for MSME Business. *Jurnal of Applied Business and Banking (JABB)*, 2(2), 129–142.
- RISSC. (2022). *The Muslim 500: The World's 500 Muslim Influential Muslims*.
- Safitri, E., & Sa'dudin, I. (2022). Reinterpretasi Makanan Halal dan Toyyib: Studi Kasus Masyarakat Muslim Pra Sejahtera di Kebumen. *Jurnal Kajian Islam Interdisipliner*, 7(1), 67–86.
- Sandria, W., Dhian Kusumawati, T., & Reza, V. (2022). An Analysis of the Impact of Promotion Strategies on Buying Decision and Buying Amount on Dunkin' Donuts Jambi, Indonesia. *International Journal of Economics Development Research*, 3(2), 84–101.
- Sanjaya, L. (2020). Analisis Pengaruh Content Marketing Pada Customer Value dan Customer Engagement Serta Dampaknya Terhadap Repeat Purchase Pada PegiPegi di Surabaya. *Jurnal Strategi Pemasaran*, 7(1), 291–303.
- Septiano, R., & Sari, L. (2021). Determination of Consumer Value and Purchase Decisions: Analysis of Product Quality, Location and Promotion. *Dinasti International: Journal of Digital Business Management*, 2(3), 482–498. <https://doi.org/10.31933/dijdbm.v2i3>
- Simanjuntak, I. I., & Surabagiarta, I. K. (2021). Pengaruh Promosi di Media Sosial Instagram dan Customer Value Terhadap Keputusan Pembelian Konsumen Kedai Renekopi di Surabaya. *Jurnal of Sustainability Business Research*, 2(2), 167–173. <https://doi.org/https://doi.org/10.36456/jsbr.v2i2.4104>
- Sugiyono. (2017). *Metode Penelitian Kuantitatif, Kualitatif, dan R&D*. Alfabeta.
- Syafrida, S., & Hartati, R. (2019). Kewajiban Sertifikat Halal Untuk Produk Impor di Indonesia. *SALAM: Jurnal Sosial Dan Budaya Syar-i*, 6(4), 363–376. <https://doi.org/10.15408/sjsbs.v6i4.13718>
- Toyo, M. (2019). Labelisasi Halal Terhadap Perilaku Konsumen Dalam Memilih Produk Makanan Sesuai Hukum Islam. *JHES: Jurnal Hukum Ekonomi Syariah*, 3(1), 69–83.
- Wartasidoarjo.Pikiran-Rakyat.com. (2021, June 15). *Halal Jadi Tren Global, Faktanya Banyak Negara Non Muslim Merajai Industri Halal*. <https://wartasidoarjo.pikiran-rakyat.com/ekonomi-bisnis/pr-1812058673/halal-jadi-tren-global-faktanya-banyak-negara-non-muslim-merajai-industri-halal>
- Wibowo, D. E., & Mandusari, B. D. (2018). Pengaruh Labelisasi Halal Terhadap Keputusan Pembelian Oleh Konsumen Muslim Terhadap Produk Makanan di Kota Pekalongan. *IJH: Indonesia Journal of Halal*, 1(1), 73–80.
- Wirakurnia, A. B., Nuanmark, P., Sudarsono, H., & Ramadhana, A. (2021). Do religiosity, halal knowledge, and halal certification affect Muslim students' intention to



purchase halal packaged food? *Asian Journal of Islamic Management (AJIM)*, 3(2), 97–110. <https://doi.org/10.20885/ajim.vol3.iss2.art3>